

## FICHE SPECIFICATIONS PRODUIT

### Gobelets 100 L « Darwin »

### Blanc/Bicolore/Translucide

	Fabricant	VENDORPLAST
	Référence	1104283 – 1104286 - 1104290
	Matière	Polystyrène Alimentaire Directives D.M. 21/03/1973 et modifications successives et/ou intégrations.
	Capacité	100 cc
	Poids unitaire	2,20 gr. (+-5%)
	Diamètre supérieur	57.5 mm
	Diamètre inférieur	33.7 mm
	Hauteur	61 mm

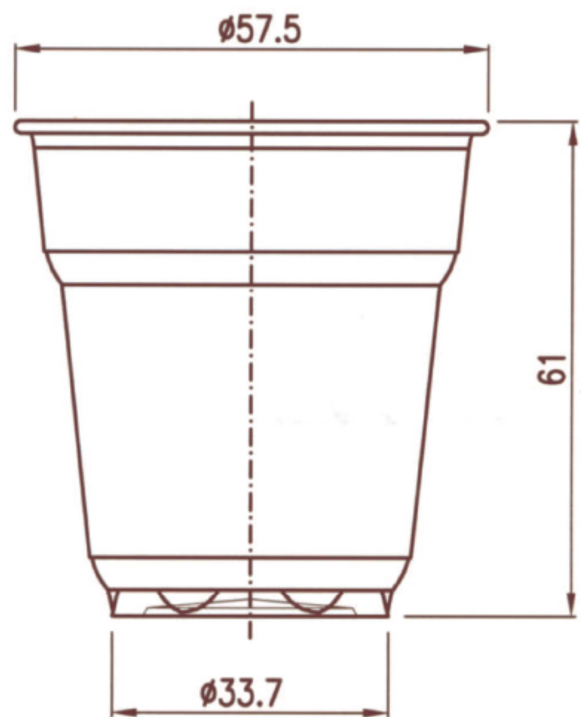

#### CONDITIONNEMENT

	Sachets /carton	50
	Gobelets / sachet	84
	Gobelets / carton	4 200
	Cartons / palette	24
	Rangs /palette	4
	Cartons / rang	6
	Hauteur Palette	208 cm
	Palette	SNCF 80x120