











FICHE SPECIFICATIONS PRODUIT







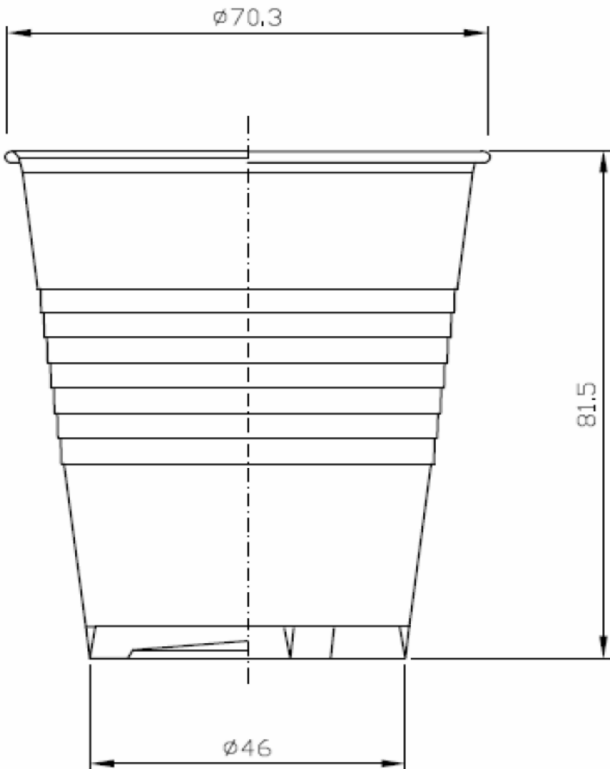

Gobelets 15 cl « 150 DA »

Blanc/Blanc-Noisette/Blanc-Brun/Moka

Usage Automatique / Empil. accrue

<ul style="list-style-type: none">  Fabricant VENDORPLAST  Référence 1405250 – 1405251 - 1405252– 1405271  Matière Polystyrène Alimentaire Directives D.M. 21/03/1973 et modifications successives et/ou intégrations.  Capacité 200 cc  Poids unitaire 3.80 gr. Tolérance (±5%)  Diamètre supérieur 70.3 mm  Diamètre inférieur 46 mm  Hauteur 81.5 mm  Traitement antistatique pour utilisation en distributeur automatique de boissons chaudes à dépilage automatique.  Empilabilité accrue 	
---	---

CONDITIONNEMENT

 Sachets /carton	30
 Gobelets / sachet	100
 Gobelets / carton	3 000
 Cartons / palette	24
 Rangs /palette	4
 Cartons / rang	6
 Hauteur Palette	224 cm
 Palette	SNCF 80 x 120